

B 246 Assembly instructions

VOSS quick connect system 246 for diesel fuel systems in automotive engineering

These assembly instructions are intended for qualified fitters of fuel systems in automotive engineering.

- PA 11 - PH - nf
- PA 11 - PHL - sw
- PA 12 - PH - nf
- PA 12 - PHL - sw
- PA 11 - PH
- PA 11 - PHL
- PA 12 - PH
- PA 12 - PHL
- PA 11 - PHLy
- PA 12 - PHLy

1. Introduction

Modern fuel systems frequently use tube assemblies made of nylon tubing. These are easy to handle and simple to install in the vehicle.

The following factors are essential for their functional reliability:

- the correct material and design to suit the type of fuel in question and the requirements placed on the fuel system
- proper handling
- the appropriate connection fittings
- correct assembly

The VOSS quick connect system 246 allows fuel lines (nylon tubing) to be connected rapidly to equipment or to other lines.

Depending on the medium, the system is available with different O-ring materials (see Section 3).

2. Nylon tubing

The VOSS quick connect system 246 is fitted with a special fir-tree on the line side. It was designed for use in fuel systems employing polyamide tubes for motor vehicles conforming to DIN 73 378 which involve the following materials:

Applications for other tubing materials and designs are available on request.

3. Range of application

The VOSS quick connect system 246 is designed for a temperature range of between -40°C and +100°C. Depending on operating conditions, it may be used at an operating pressure of up to 20 bar for nominal size NS 8 and up to 12 bar for nominal size NS 12.

The system is available with the following O-ring materials, depending on the type of fuel used:

- NBR for diesel fuel conforming to DIN EN 590
- FPM for diesel fuel conforming to DIN EN 590 and for diesel fuel made from vegetable oil methyl ester and conforming to DIN 51 606 – PME (RME)

Models for applications with other media, temperature ranges and operating pressures are available on request.

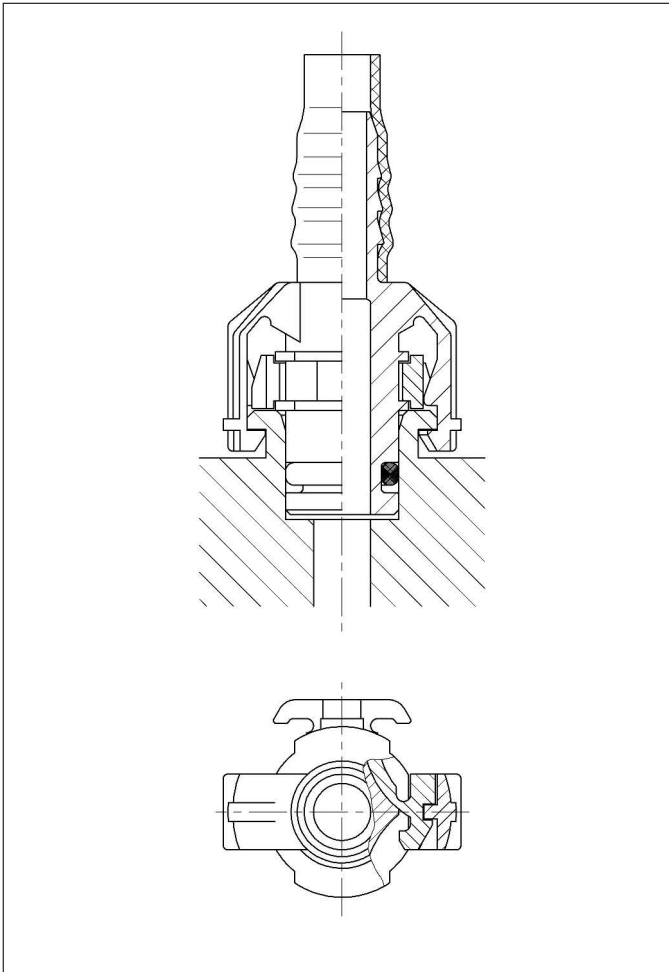

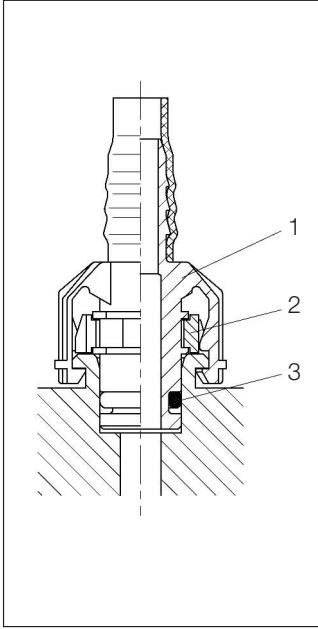

Fig. 1

4. Individual components

The VOSS quick connect system 246 consists of the plug with its fir-tree, supplemented by the release element and the O-ring seal (Fig. 1).

Application of the quick connect system is depending on the component being fitted with a connecting port as shown in Fig. 2.

A drawing with tolerances of the connecting port can be provided if required.

The VOSS quick connector system 246 is available as straight and elbow plug.

4.1 Materials

1. Quick connector with fir-tree: PA 66 GF 35, black
2. Release element: POM, natural colour
3. O-ring seal: NBR or FPM

The connecting port on components or other units should preferably be made of brass/steel.

If other materials (e.g. aluminium, glass fibre-reinforced plastics, etc.) are used, torsion-like vibrations can lead to a reduction in service life; see Section 6.5, "Routing fuel lines".

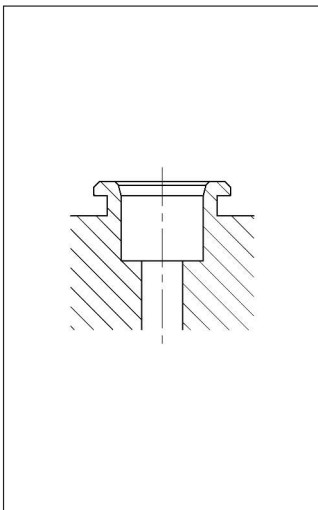

Fig. 2

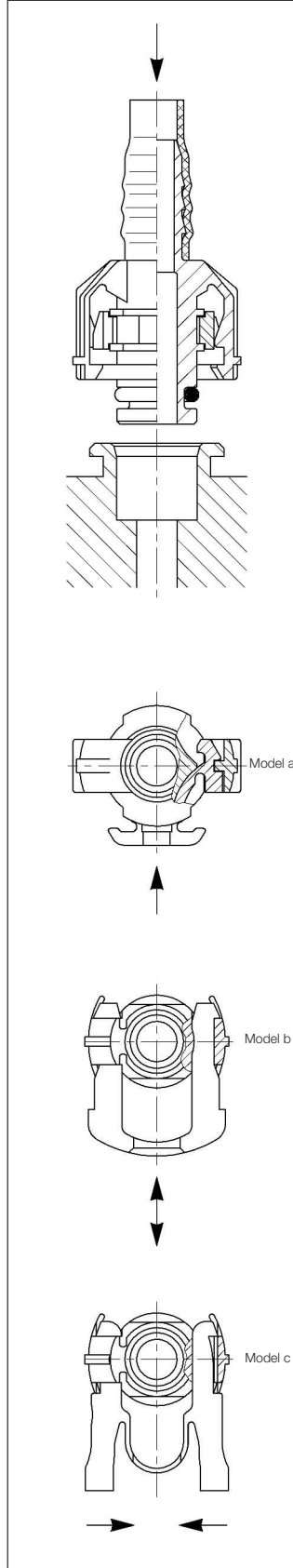

Fig. 3

5. Functional description

The fir-tree of the quick connector section should be pressed into the nylon tubing.

VOSS can provide the necessary assembly units for this operation; see Section 6.1 "Assembly of nylon tubing".

The VOSS quick connect system 246 with mounted armoured fuel line is connected to components by inserting the coupling element into the connecting port, paying special attention to the assembly instructions. In so doing, the two arms of the plug are locking behind the flange of the connecting port.

The connection is then tight.

Three different release elements are available for disassembling the connection (Fig. 3).

- Release element model a

By pressing on the release element, the snap-in hooks are spread to allow the connector to be pulled off the connecting port.

- Release element model b

To remove the quick connector, the release element must be pushed completely towards the snap-in hooks. This spreads the hooks sufficiently for the connector to be pulled off the connecting port.

The release element must be returned to its original position immediately after disconnection (see Section 6.3).

- Release element model c

By pressing together the two arms on the release element, the snap-in hooks are spread to allow the connector to be pulled off the connecting port.



Fig. 4 VOSS cutting pliers for nylon tubing

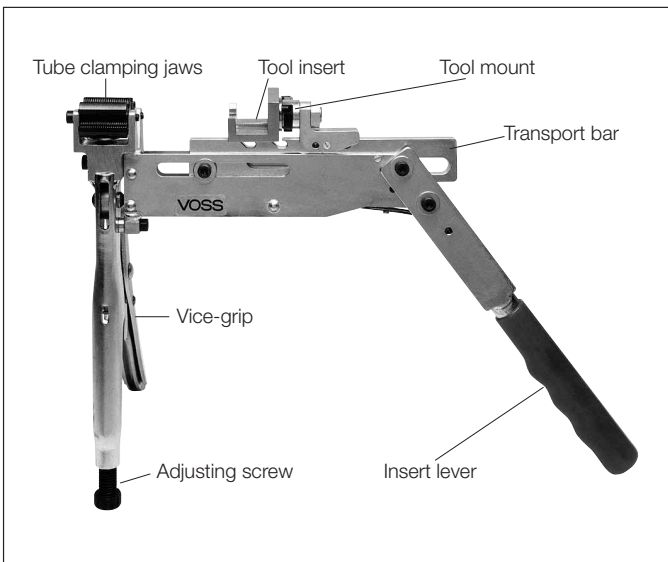

Fig. 5. VOSS Manual assembly tool

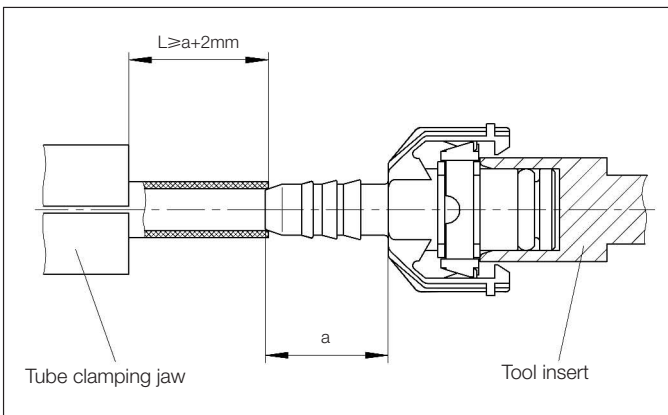

Fig. 6

Caution:

The connection between nylon tubing and fir-tree must under no circumstances be secured by hose clips or by clamping sleeves.

6. Assembly instructions

6.1 Assembly of nylon tubing

6.1.1 Cutting nylon tubing to length

The nylon tubing must be cut off square. A saw may not be used for this purpose as the formation of burrs is unavoidable; these will jeopardise the sealing capability of the connection. For cutting the nylon tubing to the correct length, we recommend the use of the VOSS cutting pliers shown in Fig. 4 which ensure that the tubing is cut squarely and cleanly. Subsequent treatment of the cut surface such as deburring is then no longer necessary.

6.1.2 Insertion of fir-tree in nylon tubing

The following is to be observed when pressing the fir-tree into the nylon tubing:

- insertion procedure must be carried out at room temperature;
- nylon tube may not be heated;
- fir-tree must be undamaged as the connection to the nylon tubing will otherwise not be tight;
- fir-tree must be clean and free of any grease.

6.1.3 Insertion of fir-tree with manual assembly tool (Figs. 5 and 6)

The tube clamping jaws should be turned in the correct direction until they match the outer diameter of the tubing to be mounted. A tool insert corresponding to the quick connector to be mounted (straight or right-angle connector) should then be placed in the tool mount.

Next place the nylon tubing into jaws, allowing it to protrude by the length L as shown in Fig. 6., and firmly secure the nylon tubing by tightening the vice-grip. The clamping force exerted may be varied by means of the adjusting screw.

The quick connector to be mounted should then be placed in the tool insert and the transport bar pressed manually towards the nylon tubing until the fir-tree is aligned with the inside diameter of the tubing.

The nylon tubing can then be pressed onto the connector as far as the end of the fir-tree by using the insert lever.

The vice-grip may now be released and the nylon tubing with mounted connector removed from the hand press.

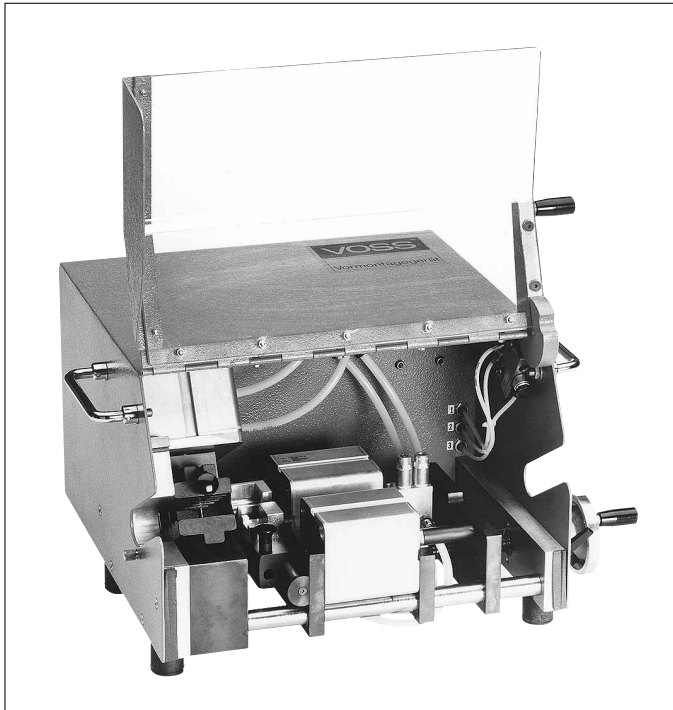

Fig. 7: VOSS type 56 assembly machine

6.1.4 Machines and tools for assembly

The following machines and tools are available from VOSS for fitting the quick connect system:

Series assembly

- VOSS type 56 assembly machine (Fig. 7) for inserting fir-trees into nylon tubing

Small series or individual assembly

- VOSS nylon tubing hand press (Fig. 5) with tool inserts
- VOSS cutting pliers for nylon tubing (Fig. 4)

Service case complete with above tools is available on request.

Caution:

Incorrectly mounted connections can result in fuel leakage and failure of the fuel system

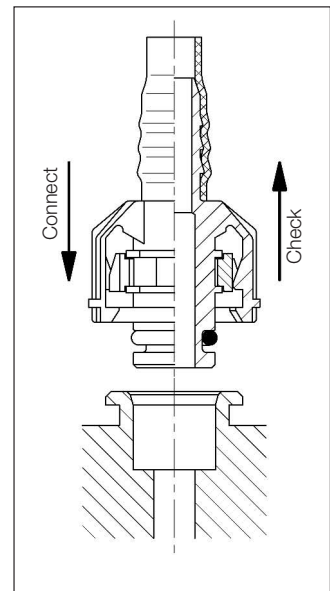

Fig. 8

6.2 Inserting quick connector into connecting port

Before inserting the connector, check the connecting port - paying particular attention to its bore-hole.

The connecting port must be clean and should not show any signs of damage.

The release element must be in its initial position, i.e. the retaining lugs are resting against the snap-in hooks.

Now insert the connector of the VOSS quick connect system 246 into the hole of the connecting port until the lateral snap-in hooks engage under the collar of the port itself. Check whether the snap-in hooks have engaged correctly by pulling in the opposite direction.

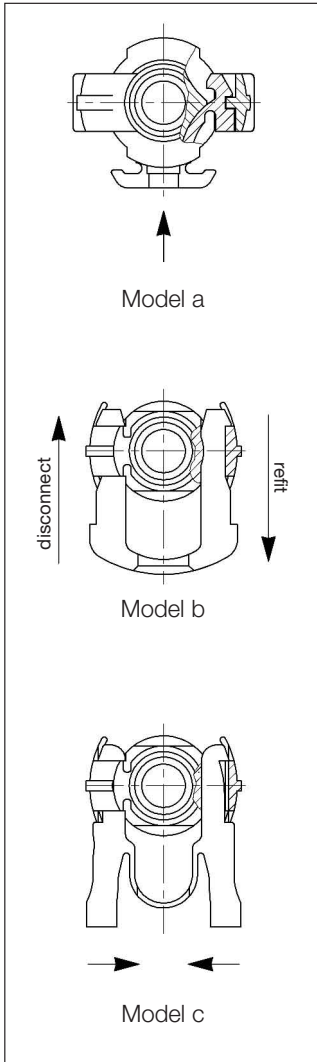

Fig. 9

6.3 Disconnecting/Refitting

6.3.1 Replacing a machine/other unit

The fuel line must be free of any pressure before disconnecting.

Disconnecting

- Release element model a

By pressing on the release element (Fig. 9a), the snap-in hooks are spread to allow the connector to be pulled off the connecting port.

- Model b release element

First push the release element (Fig. 9b) completely towards the snap-in hooks. This spreads the hooks sufficiently for the quick connector to be pulled off the connecting port. The release element must be returned to its original position immediately after removing the connector to prevent permanent deformation of the snap-in hooks.

- Model c release element

Press the two arms of the release element together (Fig. 9c) to spread the hooks sufficiently for the connector to be pulled off the connecting port.

Refitting of the connector should be carried out in accordance with the instructions in Section 6.2, "Inserting quick connector into connecting port".

6.3.2 Replacing a fuel line

Disconnect the connector as explained in the preceding section and then replace the complete defective fuel line and refit in accordance with

Section 6.2, "Inserting quick connector into connecting port".

6.4 Design of fuel lines

The fuel lines are to be designed so that they are sufficiently flexible to accommodate the required minimum free space (Fig. 10) required by the VOSS quick connect system.

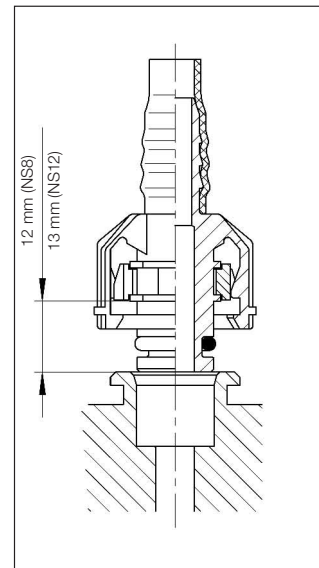

Fig. 10

6.5 Routing of fuel lines

Fuel lines are to be routed so that they are free of any stress or torsion. To prevent any damage arising from vibrations, pressure surges or bending loads, the lines must be kept stable with suitable brackets.

Caution:

Depending on the type of material combination with the connecting port, torsional vibration can result in failure of the connection. It is imperative to avoid such load conditions.

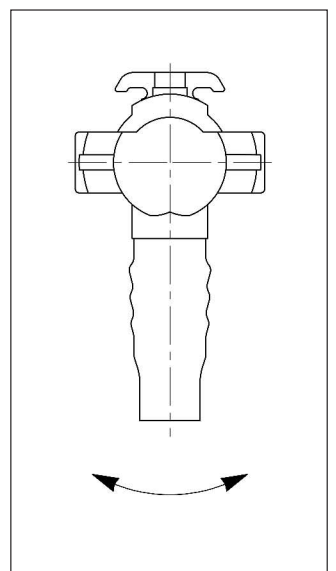

Fig. 11

The VOSS quick connect system 246 has only limited application in cases in which torsional vibrations occur as a result of various material combinations with the connecting port.

In the case of connecting ports made of aluminium or glass fibre-reinforced plastics, experiments have shown that such cases give rise to abrasion at the contact surfaces of the snap-in hooks and the connecting port itself, which may result in a reduction of service life.

Detailed test results can be requested if required.

For the reasons outlined above, the connecting ports should preferably be made of brass/steel.



VOSS customer service

The VOSS customer service is at your disposal for all questions concerning push-in connections, nylon tubing, laying of lines, etc.

Industrial property rights

We refer our customers to our national and foreign patents, registered designs, trademarks and property right applications.

Drawings of the VOSS quick connect system 246 may not be reproduced or made accessible to third parties without our prior consent.

VOSS Automotive GmbH
P.O. Box 15 40
D-51679 Wipperfürth

Leiersmühle 2-6
D-51688 Wipperfürth

Tel.: +49 2267 63-0
Fax: +49 2267 63-5982

E-Mail: automotive@voss.de
Internet: www.voss.de